

*Layouts Provided  
for New & Existing  
Refuelers!*

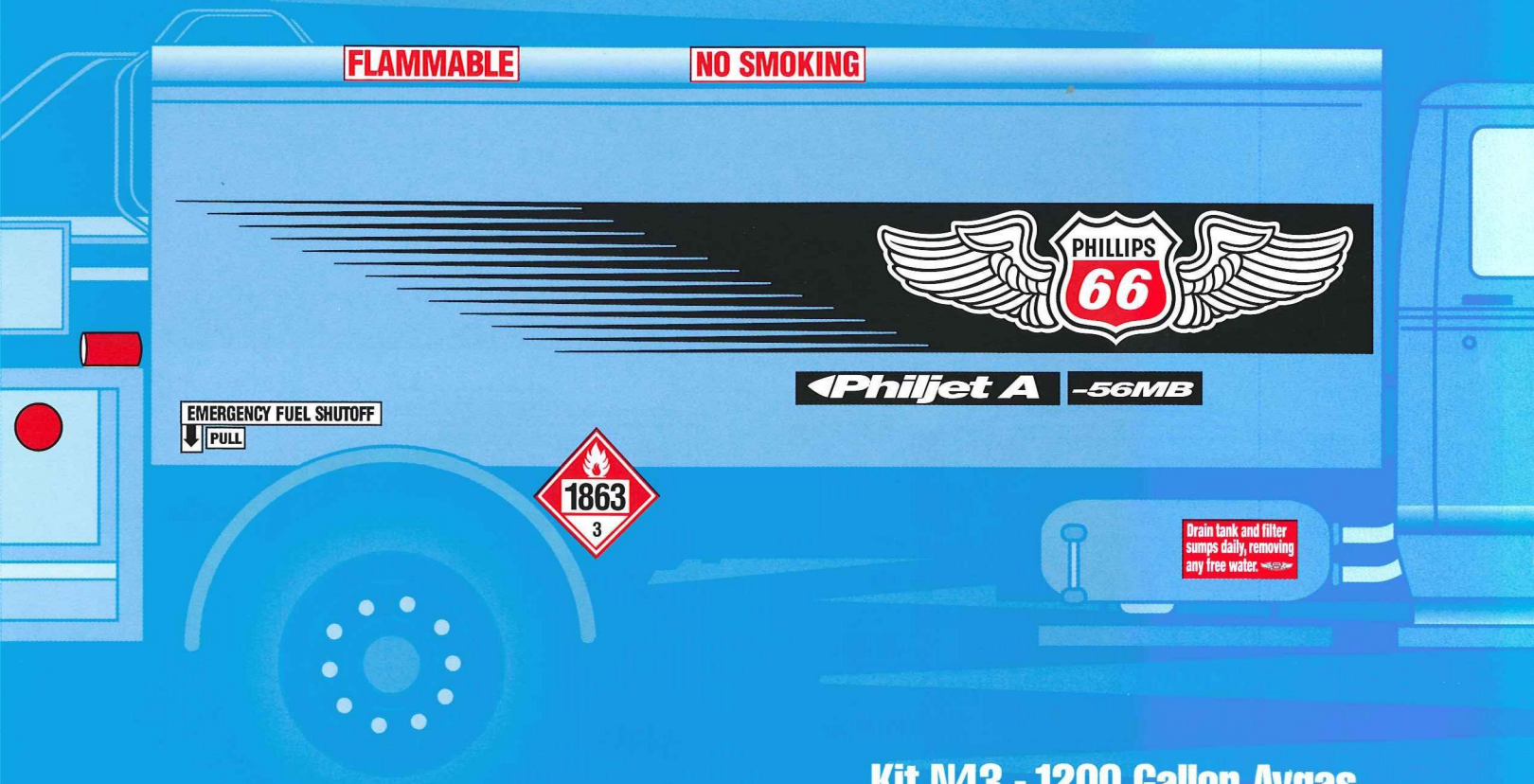

# AVIATION REFUELER

## Decal Kit Application Guide



**Kit N43 - 1200 Gallon Avgas**

**Kit N44 - 2200 Gallon Jet**

**Kit N45 - 3000 Gallon Jet**

**Kit N47 - 5000 Gallon Jet**

# 1200 Gallon Avgas Refueler

## Box Module Design

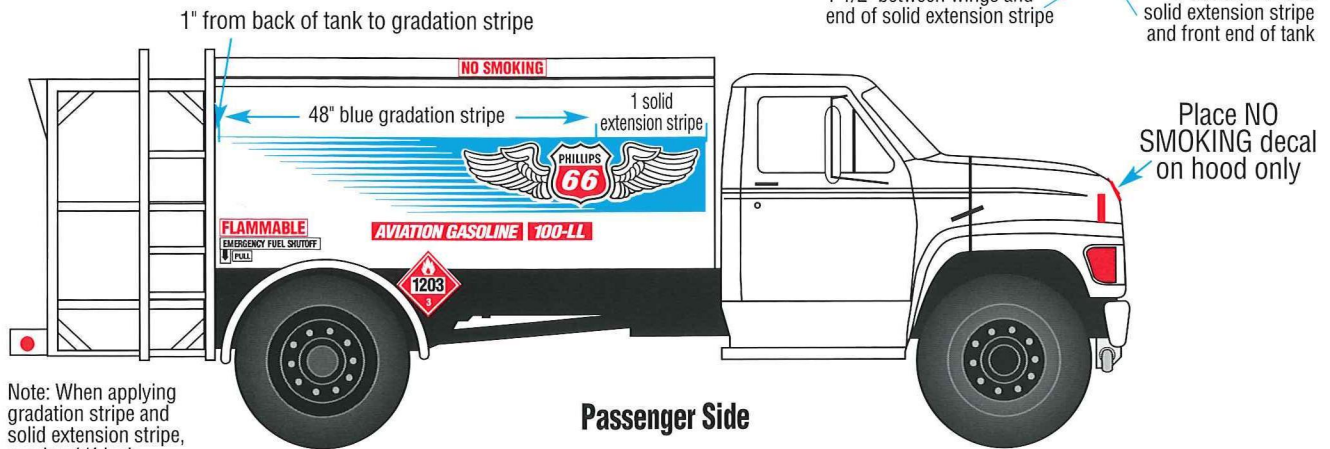
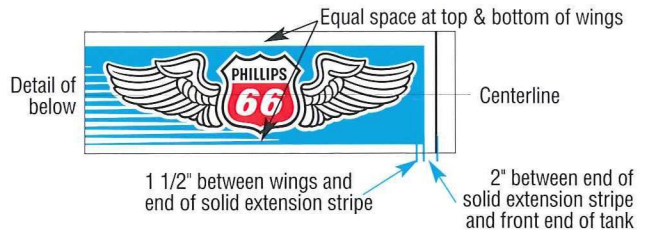

Note: When applying gradation stripe and solid extension stripe, overlap 1/4 inch

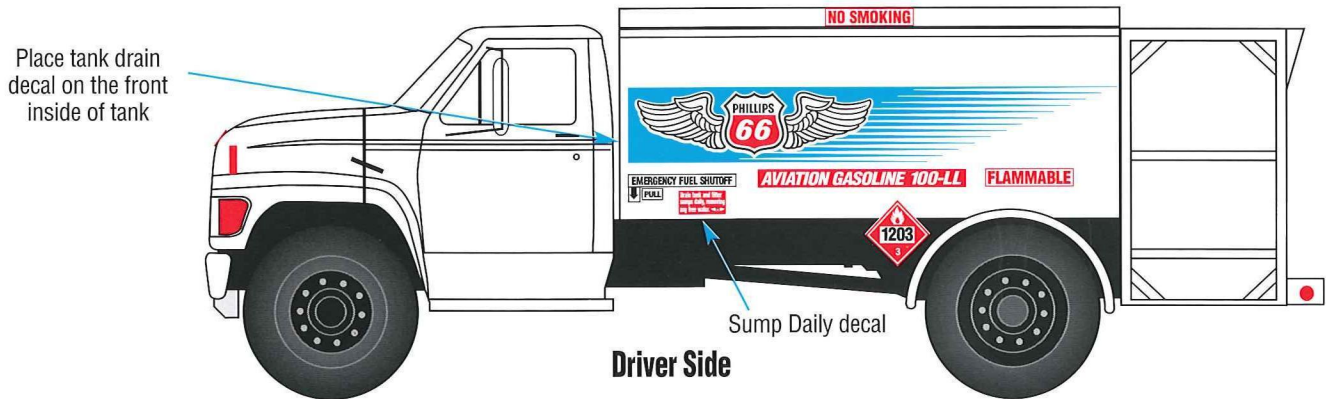

## CONTENTS OF: KIT N43 (1200 GAL. AVGAS)

### Decals and Applications

Aviation Gasoline (3) Sides & Rear

100-LL (3) Sides & Rear

D.O.T. Placards #1203 (4) Front, Sides & Rear

Emergency Fuel Shutoff (2) at Remote Controls

Push, Pull, Arrows (2) with Emergency Shutoff

Do Not Push or Pull (1) Rear

Flammable (3) Sides & Rear

No Smoking Large (4) Front, Sides & Rear

Blue Gradation Stripe - D 48" (1) Drivers Side

Blue Gradation Stripe - P 48" (1) Passenger Side

Blue Solid Extension Stripe 36" (2) 1 Each Side

Blue Rear Wings (1) Rear

Side Wings (2) Sides

No Smoking Small (1) Truck Cab Interior

Tank Drain (1) Drain Valve

Sump Daily (2) Tank Sump & Filter Sump

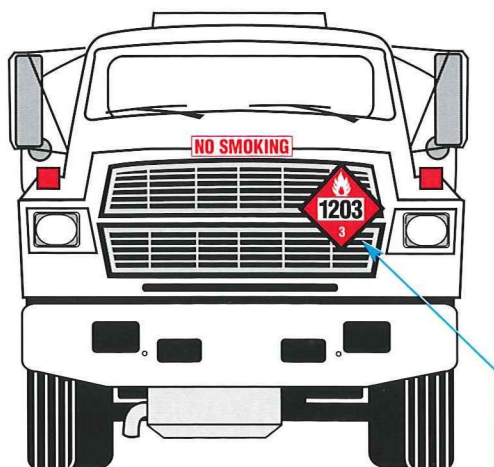

Front View

Place one placard on grill in position which least restricts airflow

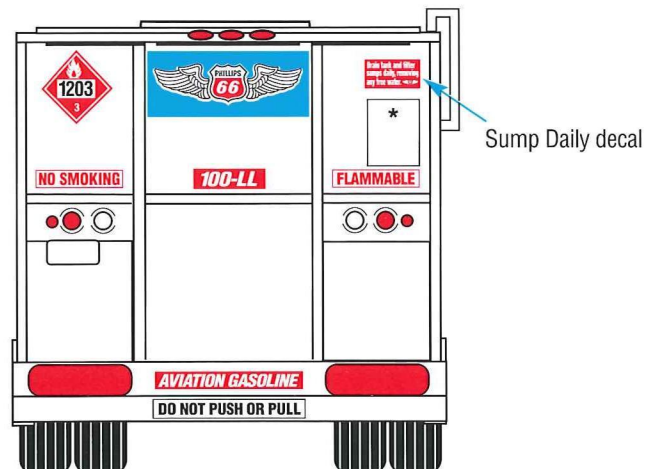

Rear View

\* OPERATING PLATE

# 2200, 3000 & 5000 Gallon Jet Refueler

## Box Module Design

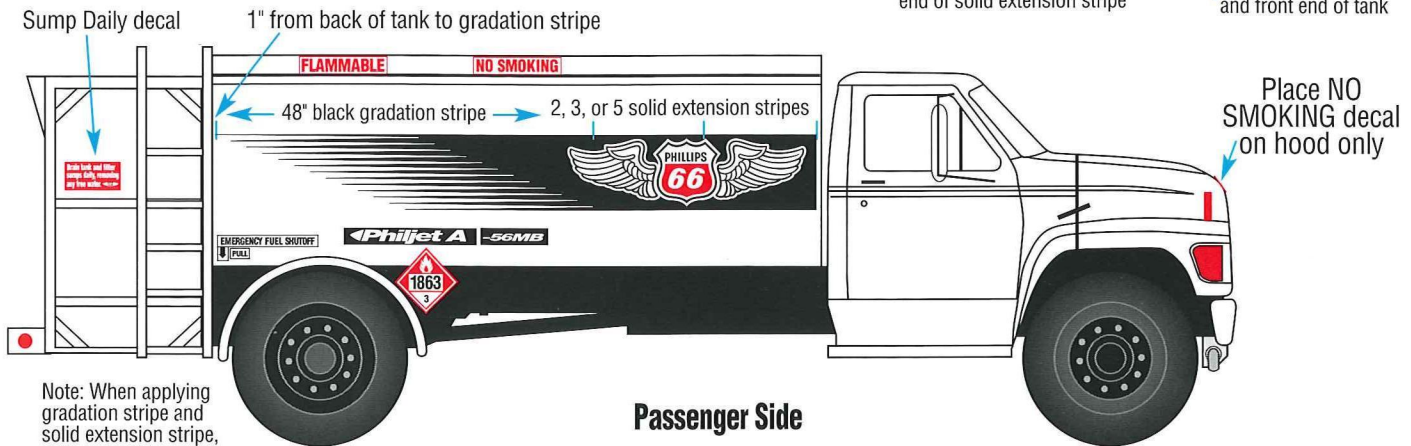

Note: When applying gradation stripe and solid extension stripe, overlap 1/4 inch

Passenger Side

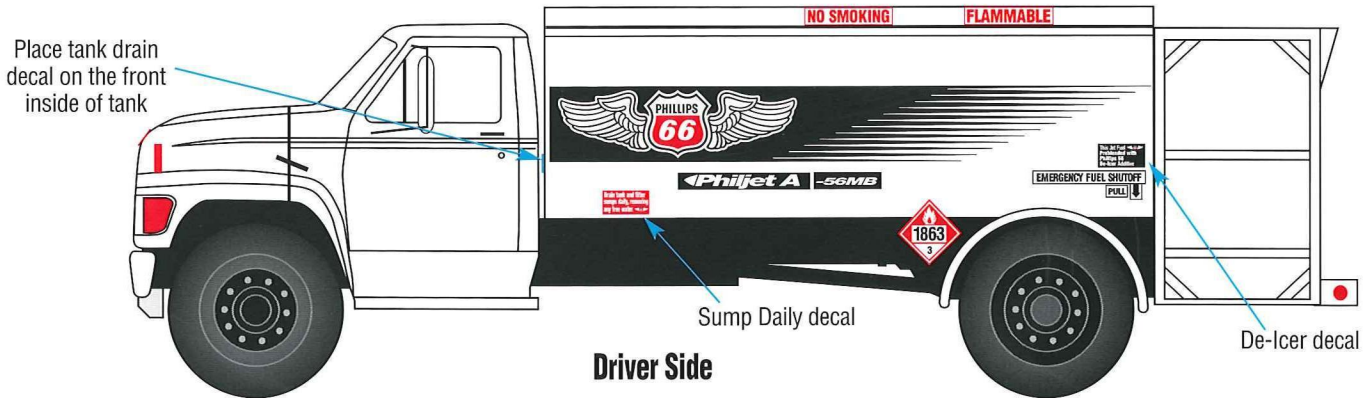

Driver Side

## CONTENTS OF: KIT N44 (2200 GAL. JET), KIT N45 (3000 GAL. JET), KIT N47 (5000 GAL. JET)

### Decals and Applications

Philjet A (3) Sides & Rear  
 56 MB (3) Sides & Rear  
 D.O.T. Placards #1863 (4) Front, Sides & Rear  
 Emergency Fuel Shutoff (2) at Remote Controls  
 Push, Pull, Arrows (2) with Emergency Shutoff

Do Not Push or Pull (1) Rear  
 Flammable (3) Sides & Rear  
 No Smoking Large (4) Front, Sides & Rear  
 Black Gradation Stripe - P 48" (1) Drivers Side  
 Black Gradation Stripe - P 48" (1) Passenger Side  
 Black Solid Extension Stripe 36" (4, 6, 10)  
 2, 3, or 5 Each Side

Black Rear Wings (1) Rear  
 Side Wings (2) Sides  
 No Smoking Small (1) Truck Cab Interior  
 Tank Drain (1) Drain Valve  
 Sump Daily (2) Tank Sump & Filter Sump  
 De-Icer Additive (2) Drivers Side Rear, Left Rear

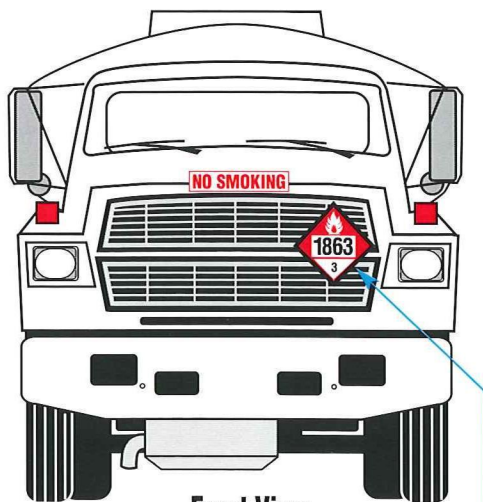

Front View

Place one placard on grill in position which least restricts airflow

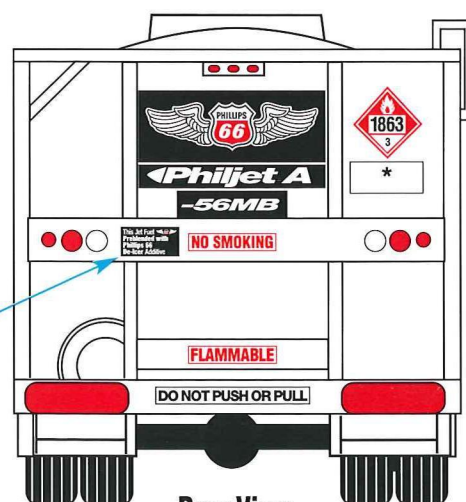

Rear View

De-Icer decal

\* OPERATING PLATE

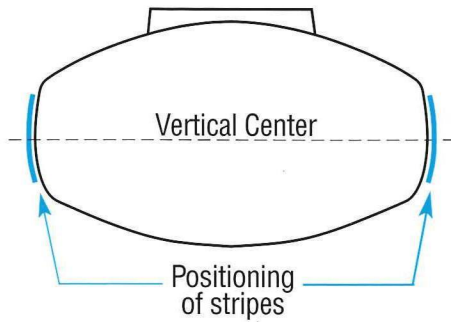
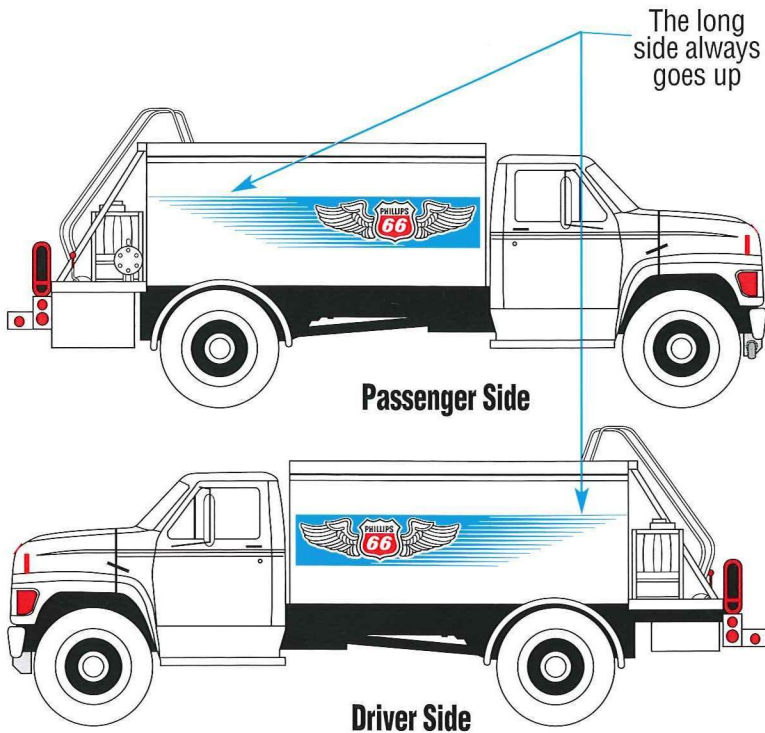

**Cross Section of Tank**

## NOTES:

- These specifications may be altered when necessary to comply with local and state regulations on coloring and lettering.
- Stainless steel and aluminum surfaces are not to be painted.
- Emergency fuel shutoff decals are to be installed at emergency trips, with arrows pointing to lever on trips.
- The tapered gradation stripe (48") must be installed first. Work from the rear of the tank to the front of the tank. Each stripe should overlap the one behind it by 1/4". The solid striping will end 2" from the front shell weld seam. **Caution**, the tapered gradation stripes are not interchangeable, there is a driver and passenger side decal. The long side always goes up. The side wings should be installed with the front tip of the wing located 1 1/2" (Avgas), 4-5" (2200 & 3000 Jet) and 8-10" (5000 Jet) from the front edge of the solid extension stripe. Center the wings vertically.
- The D.O.T. placard, 1203 or 1863 will be placed on a holder mounted on each rear wheel fender. Do not place on the tank.